



ANTI_LIGATURE ENCLOSURE

Wall Mounted Screen Enclosure

ANTI-LIGATURE TV

Introducing Ultralift Australia's Revolutionary Anti-Ligature TV Mounts and Enclosures: [A Safe and Secure Solution](#)

At Ultralift Australia, we understand the importance of creating a safe environment for individuals in all environments. Our Anti-Ligature enclosures are suitable for use in [Mental Health Facilities](#), [Aged Care](#) or [NDIS Home Care](#), [Psychiatric Hospitals](#), [Correctional Centres](#), [Youth Justice Centres](#), and [Prisons](#).

Designed to prioritize safety and well-being, our Anti-Ligature TV Mounts and Enclosures are meticulously crafted to prevent any potential harm. By eliminating the attachment points and securing all cavities and sharp corners, these innovative enclosures ensure that they cannot be used to inflict self-harm or harm others.

The key features and benefits of our Anti-Ligature TV Mounts and Enclosures include:

Comprehensive Safety: Our enclosures are engineered to leave no access points available for attachment, minimizing the risk of self-harm or harm to others. By closing all cavities and eliminating sharp corners, we provide a safe and secure solution for mounting TVs in sensitive environments.

Customized Design: We understand that every facility has unique requirements. That's why we offer custom design and manufacturing services, catering to different screen sizes and hardware specifications. Our team will work closely with you to create tailor-made enclosures that seamlessly integrate with your existing setup.

Durability and Reliability: Built to last, our Anti-Ligature TV Mounts and Enclosures are constructed using high-quality materials. They undergo rigorous testing to ensure they can withstand the demands of even the most challenging environments, providing long-lasting protection and peace of mind.

Seamless Integration: Our enclosures are designed to seamlessly blend with any interior design aesthetic. With their sleek and unobtrusive appearance, they maintain the overall ambiance of the facility without compromising on safety.

Contact our dedicated team today to discuss your specific requirements and discover how Ultralift Australia can provide you with a customized solution that prioritizes safety and peace of mind. Together, let's create a safer tomorrow.

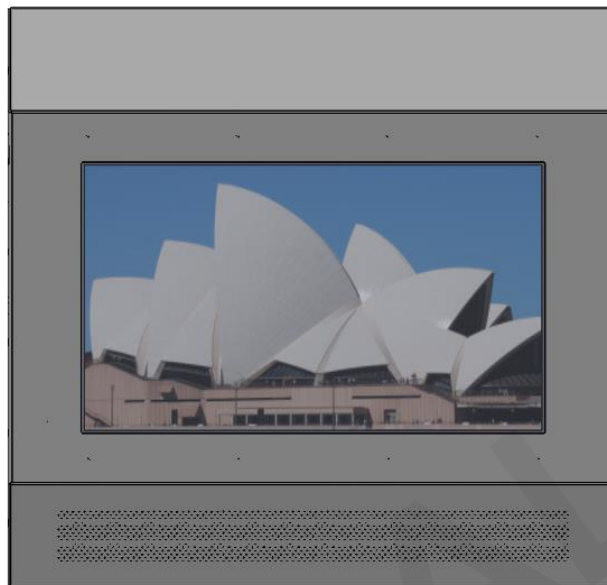

Ultralift Australia offers customizable Anti-Ligature TV Mounts and Enclosures designed to meet customers' specific requests and needs. We provide standard and customised designs; our dedicated team works closely with each customer to create a personalized solution. From screen size compatibility to hardware integration, we ensure that every aspect is tailored to exceed expectations. Contact us to discuss your customization requirements and experience our commitment to customer satisfaction. Choose Ultralift Australia for a customized and secure solution that aligns precisely with your facility's needs.

TV (Inches)	A (mm)	B (mm)	C (mm)	Approximate Weight (Kg)	Safety Shield	Thermostat + Fan	Security Screws	Colour (Powder coated) *	Anti Vandal Coating + Anti-Glare Glass
22	620	508	90	20	✓	✓	✓	Black / White	By request
24	679	495	115	23	✓	✓	✓	Black / White	By request
32	947	903	170	40	✓	✓	✓	Black / White	By request
43	1196	1042	170	60	✓	✓	✓	Black / White	By request
55	1450	1373	179	65	✓	✓	✓	Black / White	By request
65	1819	1400	179	65	✓	✓	✓	Black / White	By request
75	2045	1528	179	70	✓	✓	✓	Black / White	By request

*Other colours are available as per request.

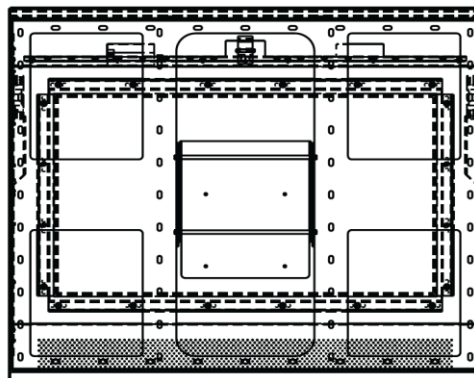
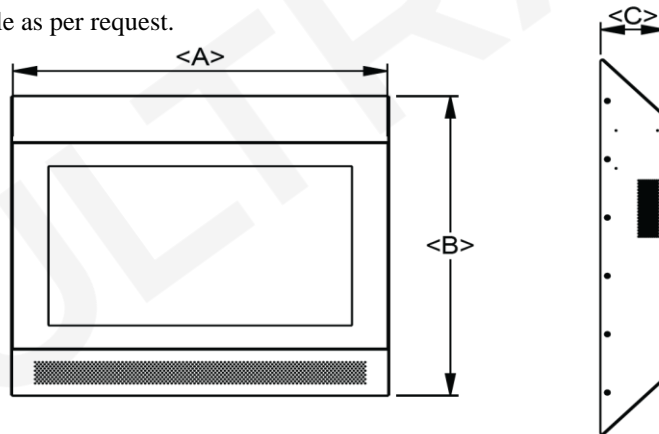

Product Assembly

Before proceeding with the installation of the Anti-Ligature Enclosure, please ensure that there is a power outlet conveniently located behind the desired mounting position. Please note that for safety purposes, there is no cable exit cut-out provided.

To begin the installation process, mount the back plate onto the wall using the provided mounting slots. To determine the exact locations of these slots, refer to the spec sheet.

Attach the TV and the Mounting bracket to the back frame of the enclosure.

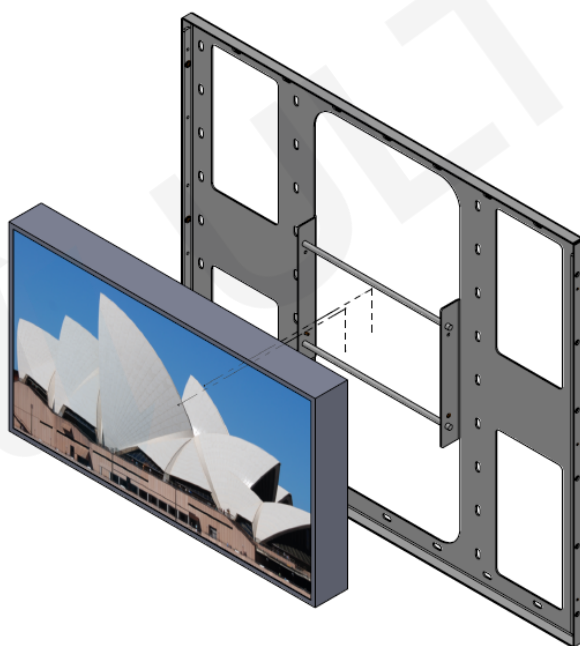
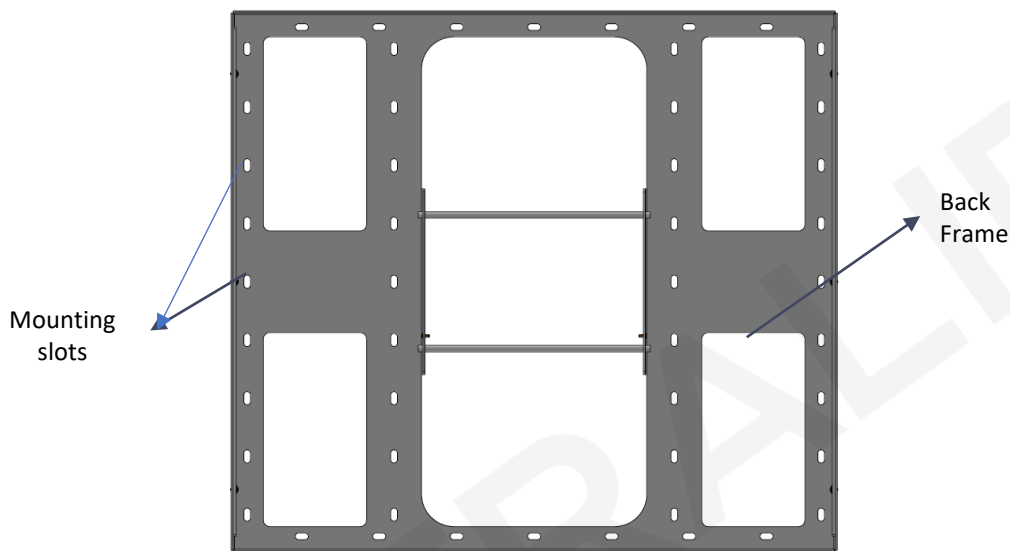

FRONT VIEW

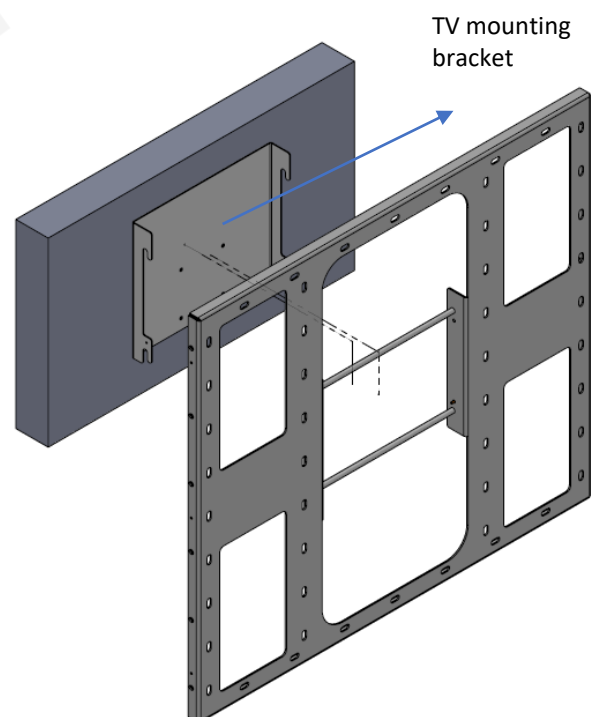

BACK VIEW

Secure the Bracket in place using M4 X 10 Button head screws on both sides.

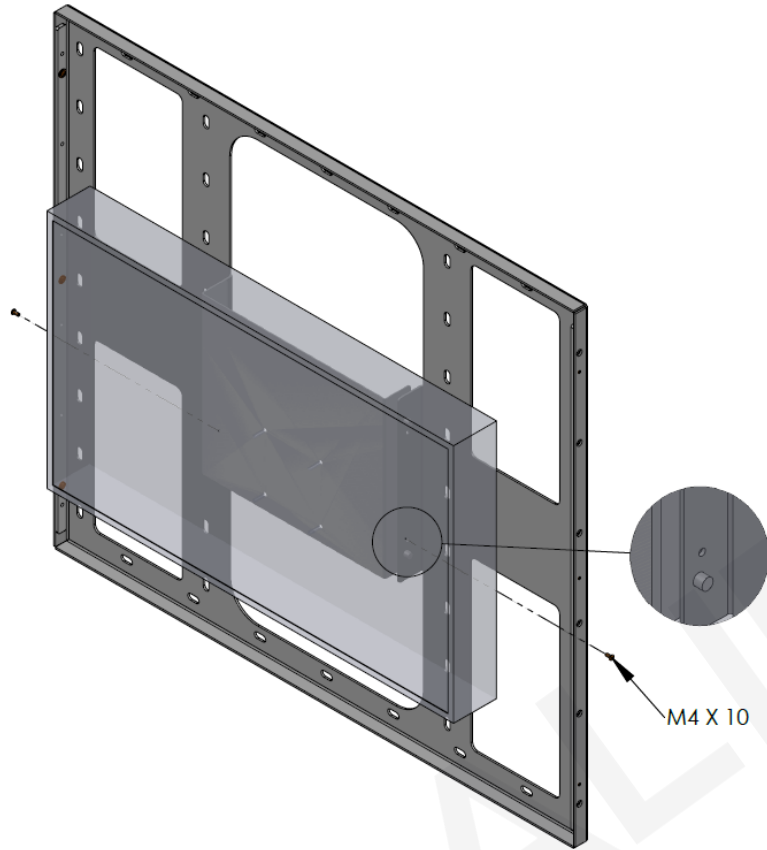

Mount the enclosure cover onto the back frame. Secure it firmly using the provided security bolts.

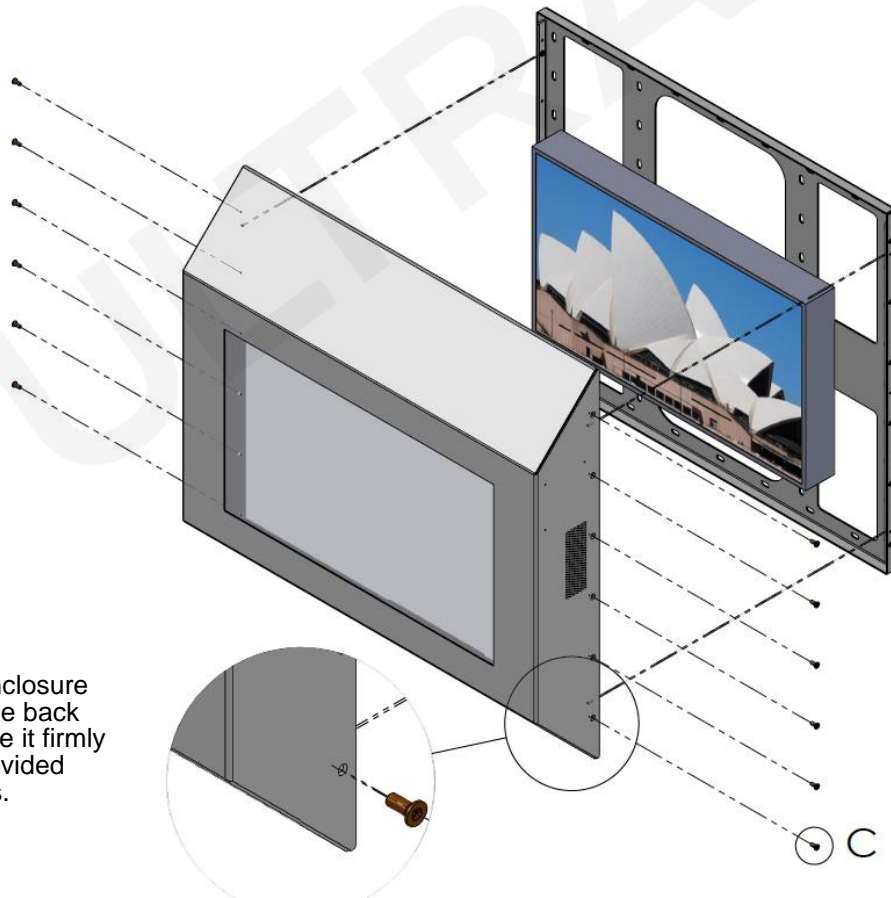

WARRANTY AND RETURNS

At Ultralift Australia Pty Ltd, we take pride in our products being of the highest quality. Because of this, we offer the following programs to ensure your satisfaction.

ULTRALIFT 3-YEAR WARRANTY

1. The product is warranted for 36 months from the invoice date. Subject to the conditions of this warranty, Ultralift Australia or an authorised installer will perform necessary service on the product without charge for parts or labour if, in the opinion of Ultralift Australia, the product is found to be faulty within the warranty period.
2. This warranty only applies to Ultralift Australia products purchased from Ultralift Australia or an authorised dealer.
3. This warranty only applies if the product has been installed and used by the manufacturer's recommendations (as noted in the instruction manual) under regular use and reasonable care (in the opinion of Ultralift Australia). The warranty covers regular domestic, commercial or educational use only. It does not cover damage, malfunction, neglect, the build-up of dirt or dust, abuse, maladjustment of customer controls, mains supply problems, thunderstorm activity, infestation by insects or vermin, tampering or repair by unauthorised persons (including unauthorised alterations), exposure to abnormally corrosive conditions or any foreign object or matter having entered the product.
4. If warranty service is required, you should:
 - Contact your installer for advice on how to rectify the issue.
 - If this does not solve the problem, please call Ultralift Australia on +61 3 9459 0873 for advice.
 - If the device requires service, return the product to Ultralift Australia for repair.
 - Please Note: You must arrange freight and insurance to and from the device's location.
 - Please ensure that items returned are packed appropriately.
5. The warranties hereby conferred do not extend to, and exclude, any costs associated with the installation, de-installation, or re-installation of a product. This includes expenses related to the mounting, de-mounting, or re-mounting any screen (and any other ancillary devices), delivery, handling, freighting, transportation or insurance of the product or any part thereof or replacement to such installation, de-installation, reinstallation, or transit.