

ATLAS LIFT

MOTORISED FLOOR LIFT

ATLAS LIFT

The Atlas lift system raises your flat-screen TV from beneath the floor, providing a comfortable viewing level and transforming any living space into an entertainment room. The Atlas range is designed to accommodate TVs installed in floor cavities, offering the extra lift required for optimal viewing.

Enhanced Lifting Capability:

The Atlas Lifts feature two lifting columns that can elevate the TV as far as 2 meters away from the floor. This extended range ensures you can achieve the perfect viewing height and create an immersive entertainment experience.

Key Features:

Suitable for TV screens **up to 100 inches**: The Atlas Lift TV System is designed to accommodate large TV screens, allowing you to enjoy a cinematic experience in the comfort of your home.

TV lowers into the floor cavity: With the Atlas Lift, your TV can be smoothly lowered into the floor cavity when not in use, providing a clean and unobstructed living space.

Renowned for smooth, quiet operation: Our lift system is known for its smooth and **quiet operation**, ensuring a seamless and enjoyable viewing experience without distracting noises.

Universal screen mount with complete fixing hardware, IR kit, and remote control: The Atlas Lift TV System has a **universal screen mount** that includes all the necessary fixing hardware for easy installation. Additionally, it is equipped with an **IR kit** and **remote control**, providing a **plug-and-play** experience.

Available Models:

Atlas 135 (ATL-135): This model offers a maximum stroke height of 1350 mm, providing ample lift for your TV.

Atlas 135 with Carcass (ATLC-135): Similar to the Atlas 135, this model includes a supporting metallic carcass for added stability and support.

Atlas 195 with Carcass (ATLC-195): Similar to the Atlas 195, this model features a supporting metallic carcass to ensure secure installation and reliable performance.

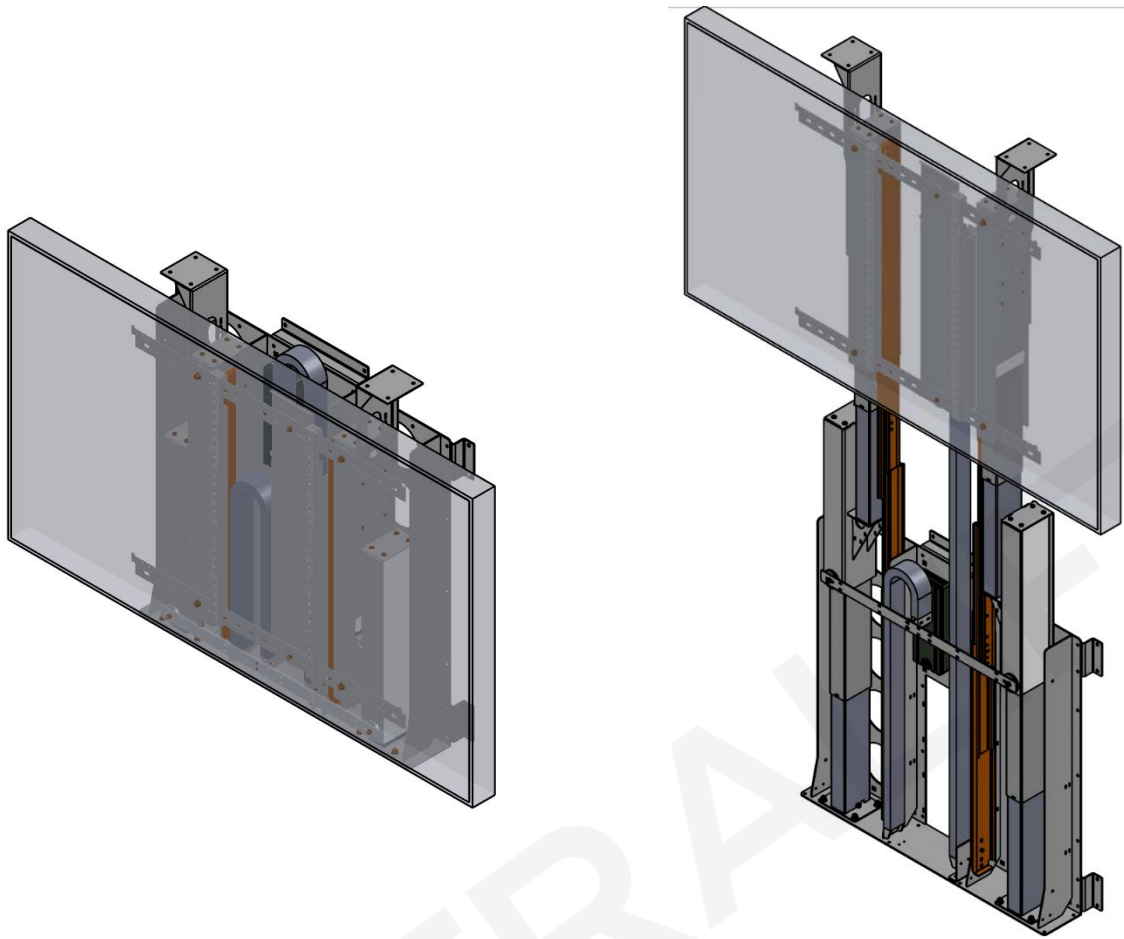

MODEL	ATLAS (ATL-000)
COLOUR*	BLACK / WHITE
LID OPENER **	HINGED LID OPENER / FIXED LID OPENER
MIN LIFT HEIGHT (BOTTOM OF TV) (mm)	30
MAX LIFT HEIGHT (BOTTOM OF TV) (mm)	1350/ 1950
MAX LOAD WEIGHT (LID + TV) (KG)	80
MAX LID WEIGHT (KG)	25
OPERATING VOLTAGE (V)	240
MAX POWER DRAW (W)	450
DRIVE TYPE	ACTUATOR
DRIVE QTY	4
DRIVE MODEL	DL-12-XL
DRIVE FORCE (N)	600
DRIVE STROKE (mm)	999
CONTROL CHANNELS	1

*Other colours are available as per request.

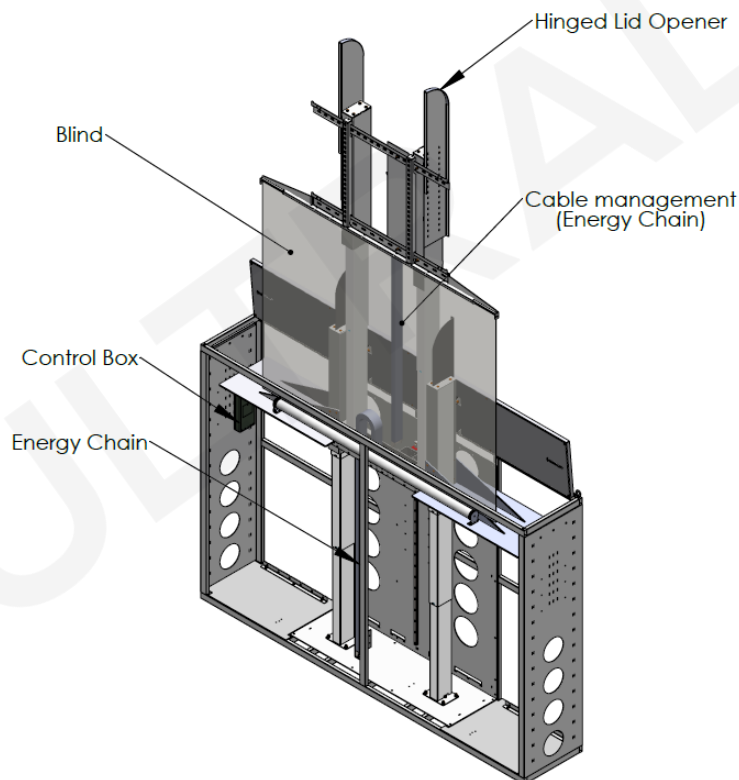

Cabinet/Joinery Not Included

Please note that the Atlas unit does not include the cabinet or joinery. To complete your setup, we advise you to contact your local carpenter or cabinet maker.

PRODUCT DIMENSIONS

Model Name	A	B	C	D	E
ATL-135	860	199	836	1101	2410

- < E > Travel distance is programmable via remote. Max stroke is 1310.
- < D > Is adjustable to suit the TV.

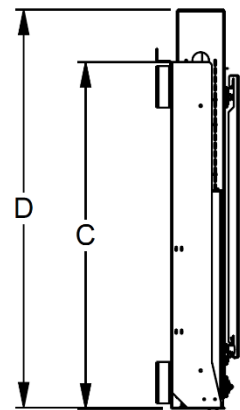
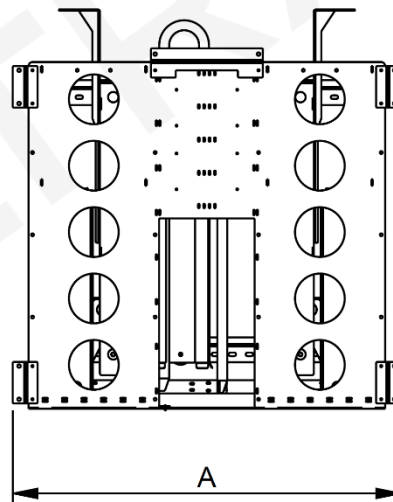
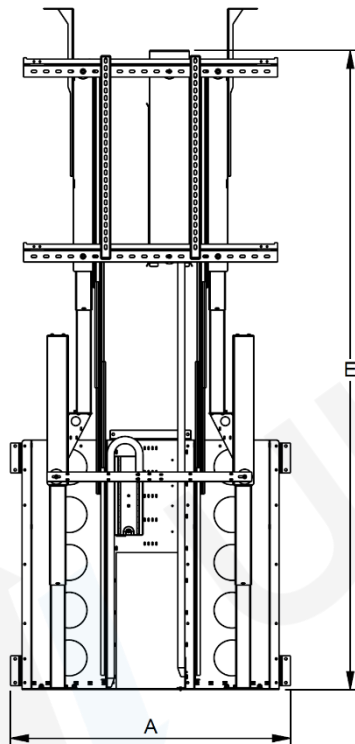
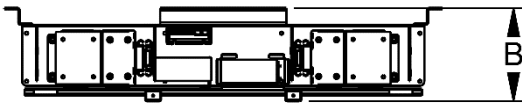

Warning: The dimensions do not provide the cut-out size.

PRODUCT DIMENSIONS**ATLAS WITH CARACAS**

The ATLC-135 & ATLC-195 are specifically designed to suit your TV and Soundbar. Please contact Ultralift Australia for the exact dimension of the product based on your TV model.

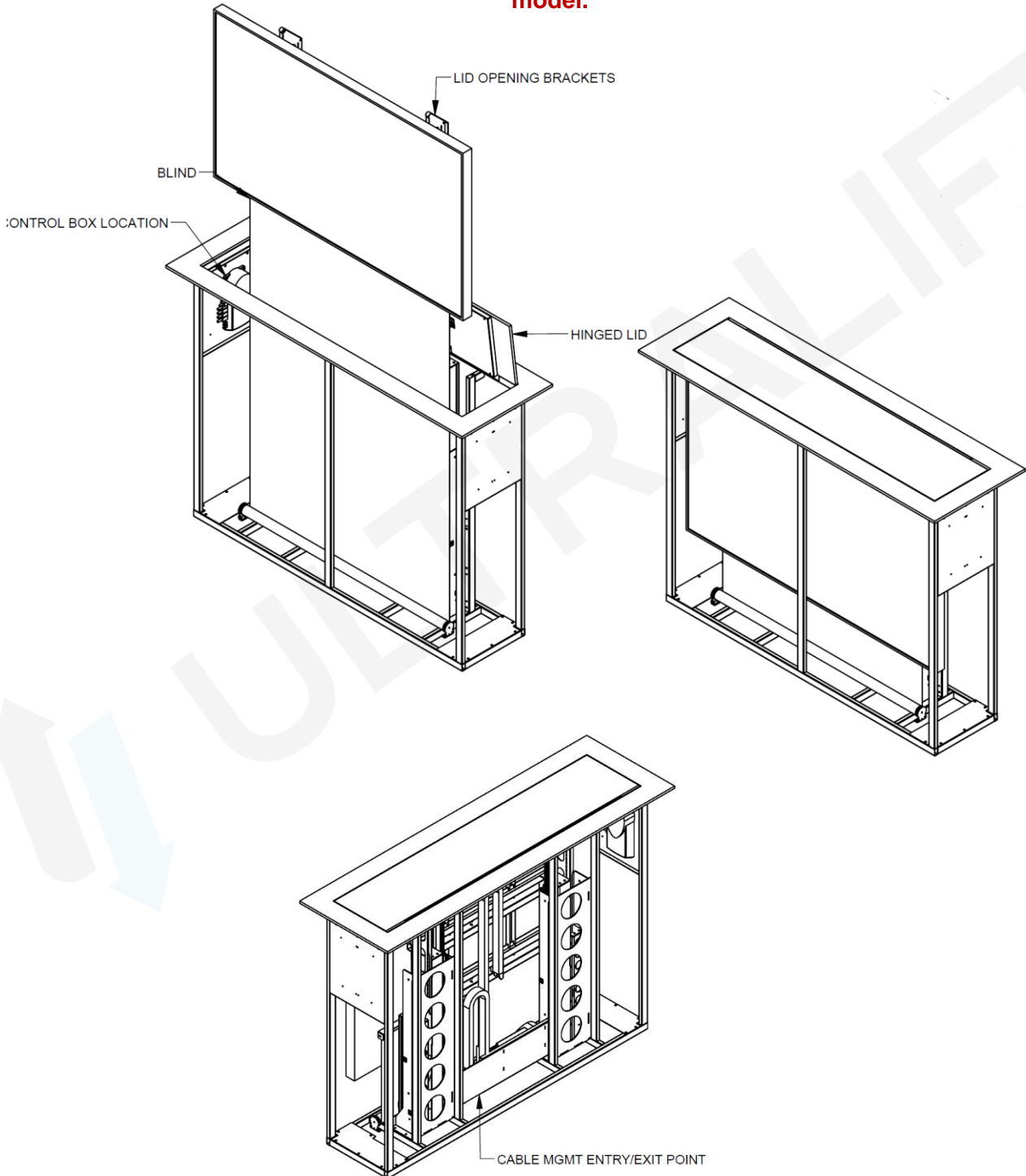

WARRANTY AND RETURNS

At Ultralift Australia Pty Ltd, we take pride in our products being of the highest quality. Because of this, we offer the following programs to ensure your satisfaction.

ULTRALIFT 3-YEAR WARRANTY

1. The product is warranted for 36 months from the invoice date. Subject to the conditions of this warranty, Ultralift Australia or an authorised installer will perform necessary service on the product without charge for parts or labour if, in the opinion of Ultralift Australia, the product is found to be faulty within the warranty period.
2. This warranty only applies to Ultralift Australia products purchased from Ultralift Australia or an authorised dealer.
3. This warranty only applies if the product has been installed and used by the manufacturer's recommendations (as noted in the instruction manual) under regular use and reasonable care (in the opinion of Ultralift Australia). The warranty covers regular domestic, commercial or educational use only. It does not cover damage, malfunction, neglect, the build-up of dirt or dust, abuse, maladjustment of customer controls, mains supply problems, thunderstorm activity, infestation by insects or vermin, tampering or repair by unauthorised persons (including unauthorised alterations), exposure to abnormally corrosive conditions or any foreign object or matter having entered the product.
4. If warranty service is required, you should:
 - Contact your installer for advice on how to rectify the issue.
 - If this does not solve the problem, please call Ultralift Australia on +61 3 9459 0873 for advice.
 - If the device requires service, return the product to Ultralift Australia for repair.
 - Please Note: You must arrange freight and insurance to and from the device's location.
 - Please ensure that items returned are packed appropriately.
5. The warranties hereby conferred do not extend to, and exclude, any costs associated with the installation, de-installation, or re-installation of a product. This includes expenses related to the mounting, de-mounting, or re-mounting of any screen (and any other ancillary devices), delivery, handling, freighting, transportation or insurance of the product or any part thereof or replacement to such installation, de-installation, reinstallation, or transit.